

BNB Industries, Inc.

PO Box 963, Alvarado Texas 76009-0963 (mailing)
 2301 Webb Lynn Road, Arlington, Texas 76018 (mfg)
 Ph: 817-465-9226 E-mail: email@bnb-industries.com
 Fax 817-465-8305 Web Site: www.bnb-industries.com

**CONVEYOR ROLLERS
 TAPERED STYLE**

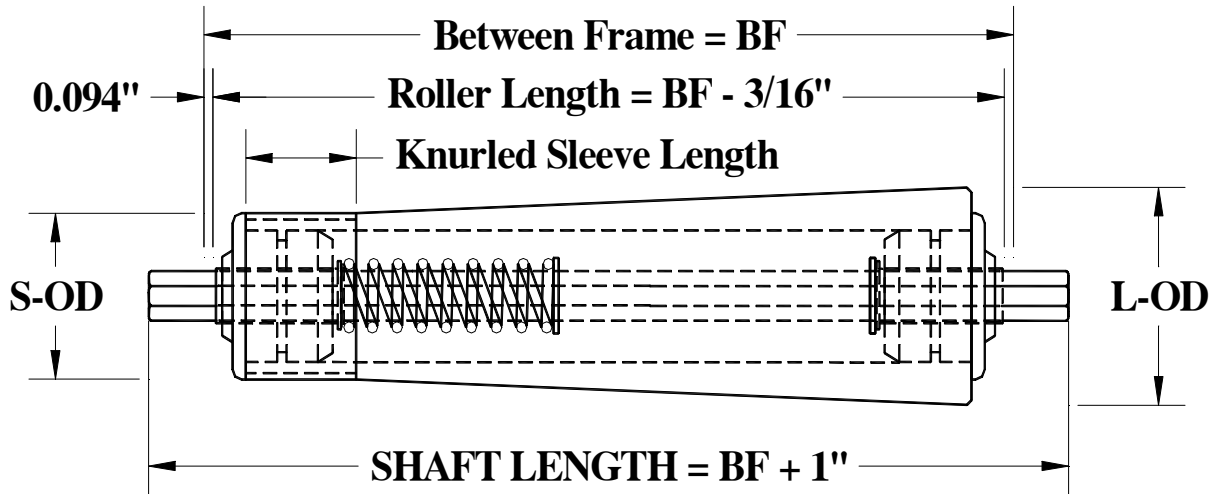

Spring loaded or pin retained tapered rollers are for V-Belt driven live roller curves used in corrosive, wash down or food handling environments. To order these rollers specify the material the roller is to be manufactured from, the outside diameter of the large and small end of the roller, the frame to centerline location of the V-Belt, the between frame dimension and the shaft size and material type.

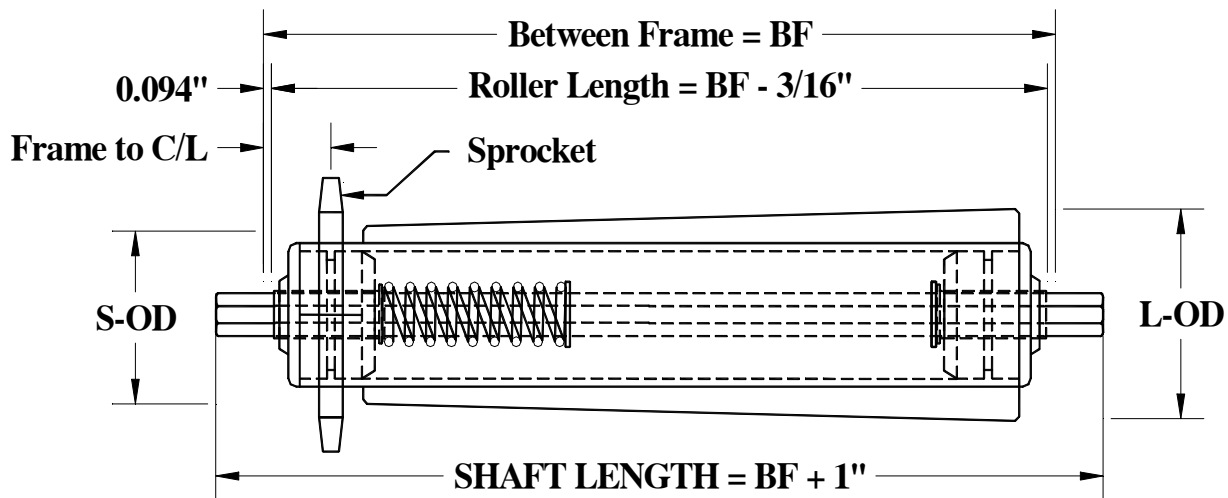

Spring loaded or pin retained tapered rollers are for chain driven live roller curves used in corrosive, wash down or food handling environments. To order these rollers specify the material the roller is to be manufactured from, the outside diameter of the large and small end of the roller, the pitch and number of teeth, material and frame to centerline location of the sprocket, the between frame dimension and the shaft size and material type.

Special components and materials are available upon request, please consult BNB for further information.